

DDL-5530N SERIES

MACHINE FRAME & MISCELLANEOUS COVER COMPONENTS

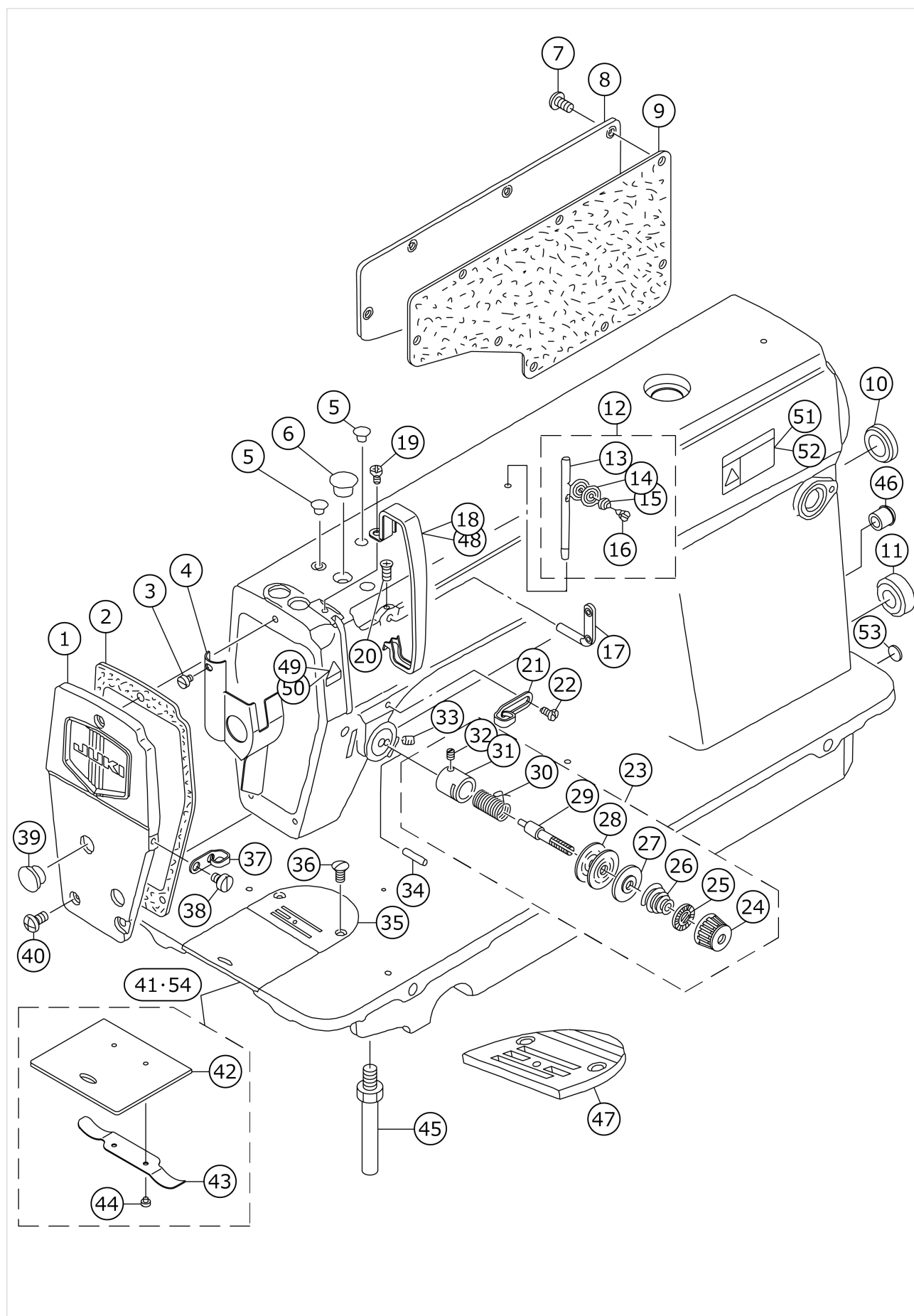

No.	parts number	parts name	comment	child	num
1	11070851	FACE PLATE ASM.			1.00
2	11000304	FACE PLATE GASKET			1.00
3	SS6080410SP	SCREW 1/8-44 L=4			1.00
4	22900757	FACE PLATE OIL SHIELD ASM.			1.00
5	TA0850604R0	RUBBER PLUG			2.00
6	TA1250705R0	RUBBER PLUG			1.00
7	SS4120915SP	SCREW 3/16-28 L=9			8.00
8	11070901	SIDE PLATE			1.00
9	11003308	GASKET			1.00
10	TA2000502R0	RUBBER PLUG			1.00
11	TA2101002R0	RUBBER PLUG			1.00
12	22932552	NEEDLE THREAD GUIDE PIN ASM.			1.00
13	22932503	THREAD GUIDE ROD			1.00
14	22932602	THREAD GUIDE DISK			2.00
15	22932701	THREAD GUIDE DISK SPRING			1.00
16	SD0380552SL	HINGE SCREW D=3.8 H=5.5			1.00
17	22920706	TWO EYELET			1.00
18	22900609	THREAD TAKE-UP LEVER COVER			1.00
19	SS4120615SP	SCREW 3/16-28 L=6			1.00
20	SS4120615SP	SCREW 3/16-28 L=6			1.00
21	22920508	ARM THREAD GUIDE A			1.00
22	11001500	SCREW			1.00
23	22945356	THREAD TENSION ASM.			1.00
24	22921308	THREAD TENSION NUT			1.00
25	22921407	ROTATION STOPPER			1.00
26	22921704	THREAD TENSION SPRING, A			1.00
27	22921803	DISK STOPPER			1.00
28	22921506	THREAD TENSION DISK			2.00
29	22921209	THREAD TENSION POST			1.00
30	22921605	THREAD TAKE-UP SPRING			1.00
31	22945307	THREAD TENSION POST BASE			1.00
32	SS8090670SP	SCREW 9/64-40 L= 5.5			1.00
33	SS8150710TP	SCREW 15/64-28 L=7			1.00
34	22920904	PIN			1.00
35	B1109012A00	THROAT PLATE (A)			1.00
36	SS2110920TP	SCREW 11/64-40 L=8.5			2.00
37	22920607	ARM THREAD GUIDE B			1.00
38	SS6110610TP	SCREW 11/64-40 L=6			1.00
39	TA1250406R0	RUBBER PLUG D=12.5 L=4			2.00
40	SS4120915SP	SCREW 3/16-28 L=9			3.00
41	22901250	SLIDE PLATE ASM.			1.00
42	22901201	SLIDE PLATE			1.00
43	22901300	SLIDE PLATE SPRING			1.00
44	SS6060210SP	SCREW 3/32-56 L= 1.9			2.00
45	22901003	BED SCREW STUD			4.00
46	TA0950806R0	RUBBER PLUG			1.00
47	B1109552000	THROAT PLATE	FOR JA,JH		1.00
48	22901904	THREAD TAKE-UP LEVER COVER	FOR JE		1.00
49	CM300200001	ATTENTION SEAL	FOR JE		1.00
50	CM3002000B1	LABEL(16)	FOR USE IN JAPAN		1.00

51	CM300200101	SAFETY LABEL, 1(SMALL).	FOR USE IN JAPAN			1.00
52	CM3002001A1	SAFETY LABEL.,3 (SMALL).	EXCEPT JE & USE IN JAPAN			1.00
53	10004109	GROUND MARK				1.00
54	11003258	SLIDE PLATE ASM.	FOR JH			1.00

MAIN SHAFT & THREAD TAKE-UP LEVER COMPONENTS

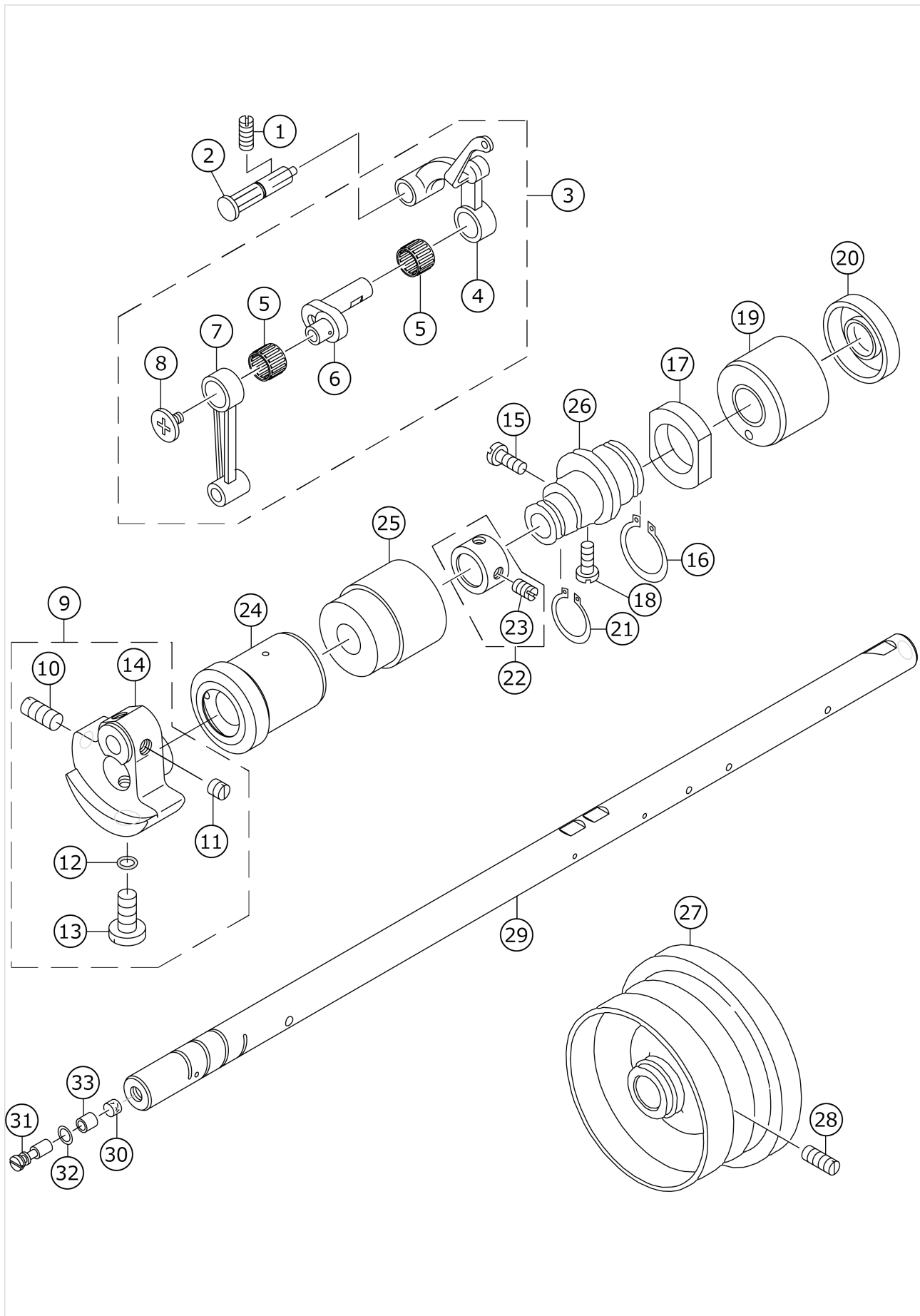

No.	parts number	parts name	comment	child	num
1	SS8151150TP	SCREW 15/64-28 L=10.5			1.00
2	22919559	THREAD TAKE-UP CRANK SHAFT ASM			1.00
3	11017076	LINK THREAD TAKE-UP LEVER ASM.			1.00
4	11017068	LINK THREAD TAKE-UP LEVER ASM.			1.00
5	B1905541B00	NEEDLE BEARING	SELECTIVE PARTS		2.00
6	11005204	NEEDLE BAR CRANK			1.00
7	B1408552000	NEEDLE BAR CRANK ROD			1.00
8	B1903552000	LEFT SCREW			1.00
9	22903157	COUNTER WEIGHT ASM.			1.00
10	SS8681650TP	SCREW 9/32-28 L=16			1.00
11	SS8660610TP	SCREW 1/4-40 L=6			2.00
12	RO044240100	RUBBER RING			1.00
13	SS7681650TP	SCREW 9/32-28 L=16			1.00
14	22903108	COUNTER WEIGHT			1.00
15	SS6661110SP	SCREW 1/4-40 L=11			1.00
16	RC2501211KP	SNAP RING 25.0			1.00
17	11050101	PITMAN SLEEVE			1.00
18	SS6661110SP	SCREW 1/4-40 L=11			1.00
19	11002409	MAIN SHAFT BUSHING, REAR			1.00
20	11002508	OIL SEAL			1.00
21	RC1850001KP	SNAP RING 18.5			1.00
22	22904155	MAIN SHAFT THRUST COLLAR ASM.			1.00
23	SS8660610TP	SCREW 1/4-40 L=6			2.00
24	22903207	MAIN SHAFT BUSHING, FRONT			1.00
25	22903306	BUSHING,INTERMEDIATE			1.00
26	11050002	FEED CAM			1.00
27	11071305	HAND WHEEL			1.00
28	SS8151550SP	SCREW 15/64-28 L=15			2.00
29	22903009	MAIN SHAFT			1.00
30	11002904	ROLLER FELT			1.00
31	22903900	ADJUSTING PIN			1.00
32	RO029180100	RUBBER RING			1.00
33	B1215552000	OIL ADJUSTING COLLAR			1.00

NEEDLE BAR, UPRIGHT SHAFT & HOOK DRIVING SHAFT COMPONENTS

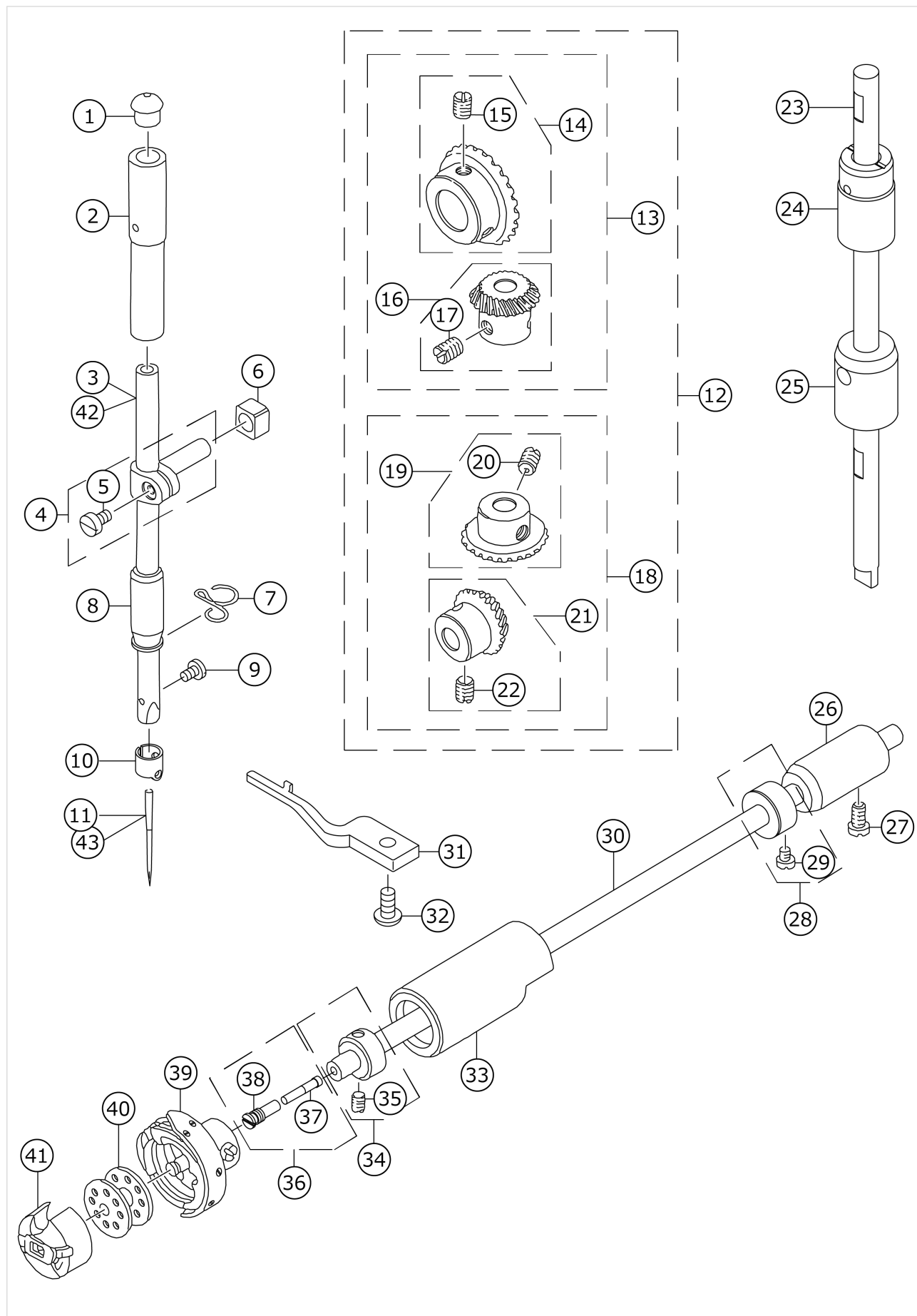

No.	parts number	parts name	comment	child	num
1	22901409	NEEDLE BAR UPPER BUSH CAP			1.00
2	22906101	NEEDLE BAR BUSHING, UPPER			1.00
3	22906002	NEEDLE BAR			1.00
4	22906457	NEEDLE BAR CONNECTING ASM.			1.00
5	SS6090670TP	SCREW 9/64-40 L=6			1.00
6	B1414555000	SLIDE BLOCK			1.00
7	22920805	NEEDLE BAR THREAD GUIDE			1.00
8	B1403155000	NEEDLE BAR BUSHING, LOWER			1.00
9	SS7080510TP	SCREW 1/8-44 L=4.5			1.00
10	22906309	NEEDLE BAR THREAD GUIDE			1.00
11	MDB100B1400	NEEDLE DBX1 #14			1.00
12	B13061550C0	GEAR & PINION ASM.			1.00
13	B13061550B0	GEAR & PINION ASM., UPPER			1.00
14	B13050120A0	GEAR ASM.			1.00
15	SS8660810TP	SCREW 1/4-40 L=8			2.00
16	B13061550A0	PINION ASM.			1.00
17	SS8660810TP	SCREW 1/4-40 L=8			2.00
18	B13071550B0	GEAR & PINION ASM., LOWER			1.00
19	B13071550A0	GEAR ASM. LARGE			1.00
20	SS8660810TP	SCREW 1/4-40 L=8			2.00
21	B13081550A0	PINION ASM.			1.00
22	SS8660810TP	SCREW 1/4-40 L=8			2.00
23	22905004	UPRIGHT SHAFT			1.00
24	22905103	BUSHING B, UPPER			1.00
25	11004207	UPRIGHT SHAFT BUSHING, LOWER			1.00
26	11015807	BUSHING, REAR			1.00
27	SS4120915SP	SCREW 3/16-28 L=9			1.00
28	22917157	THRUST COLLAR ASM. D=7.94 W=10			1.00
29	SS6110420TP	SCREW 11/64-40 L=4.8			2.00
30	22916001	HOOK DRIVING SHAFT			1.00
31	22916407	BOBBIN CASE HOLDER			1.00
32	SS4110915TP	SCREW 11/64-40 L= 9.5			1.00
33	22916100	BUSHING ASM., FRONT			1.00
34	22917058	THRUST COLLAR ASM.			1.00
35	SS8110410TP	SCREW 11/64-40 L= 3.5			2.00
36	22916555	OIL SEAL SCREW ASM.			1.00
37	11015906	OIL WICK			1.00
38	22916506	SET SCREW			1.00
39	B18301270A0	HOOK ASM.			1.00
40	22932909	BOBBIN			1.00
41	B18370120A0	BOBBIN CASE ASM.			1.00
42	11141108	NEEDLE BAR	FOR JE		1.00
43	MC200500750	NEEDLE 134 NM75	FOR JE		1.00

HAND LIFTER COMPONENTS

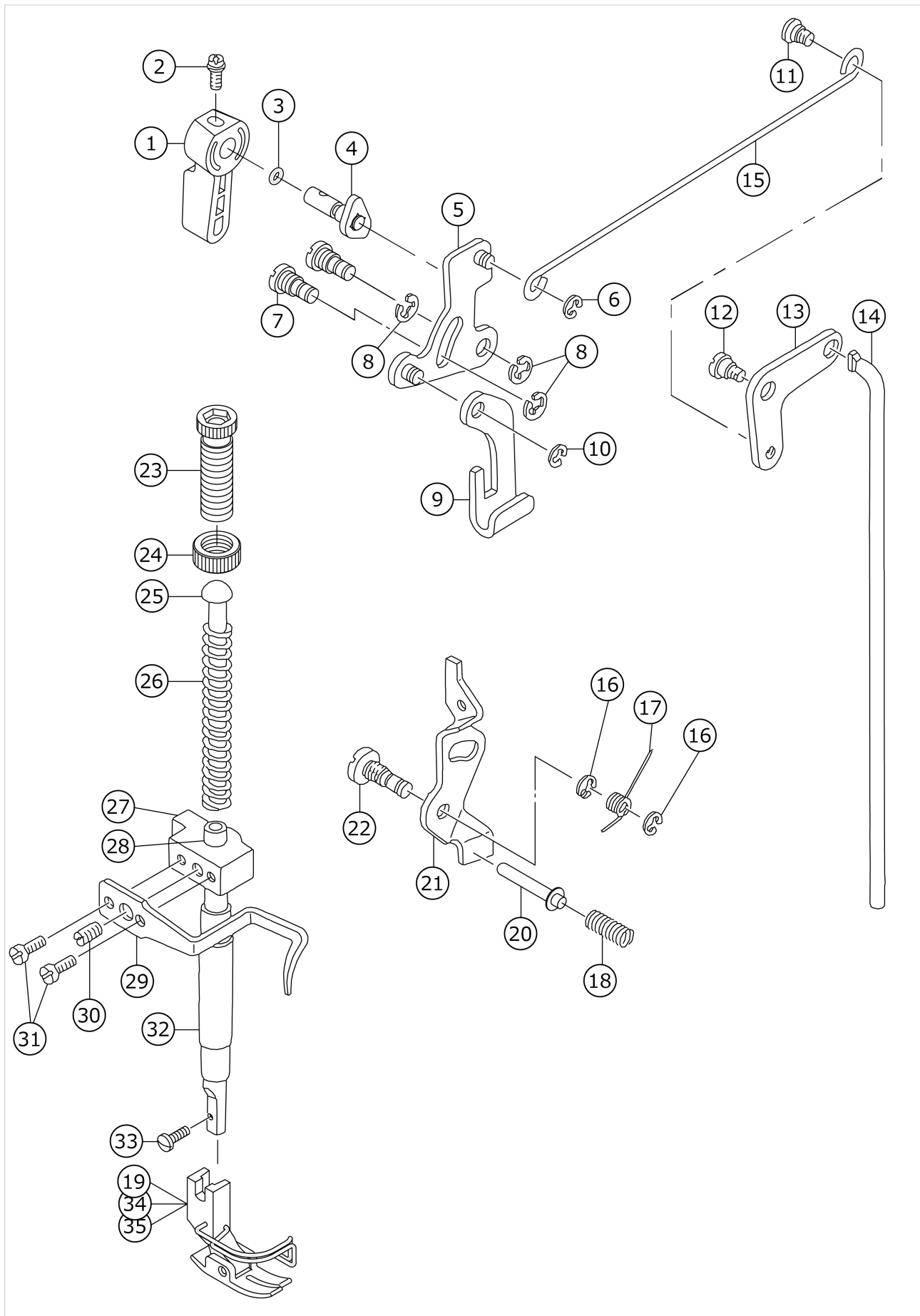

No.	parts number	parts name	comment	child	num
1	22907802	HAND LIFTER			1.00
2	B1521555000	SCREW			1.00
3	RO037180100	RUBBER RING			1.00
4	22908552	HAND LIFTER CAM ASM.			1.00
5	22908156	LIFTING LINK ASM.			1.00
6	RE0500000K0	E-RING			1.00
7	11006509	LINK SHAFT			2.00
8	RE0500000K0	E-RING			3.00
9	22908008	LIFTING PLATE			1.00
10	11007309	E-RING			1.00
11	22908909	HINGE SCREW			1.00
12	SD0720331SP	HINGE SCREW D= 7.24 H= 3.3			1.00
13	22908800	KNEE LIFTER LINK			1.00
14	22909006	KNEE LIFTER CONNECTING ROD			1.00
15	22908305	KNEE LIFTER SIDE ROD			1.00
16	RE0500000K0	E-RING			2.00
17	11018207	TENSION RELEASE RETURN SPRING			1.00
18	11018405	TENSION RELEASE PIN SPRING			1.00
19	B15240120BA	PRESSER FOOT ASM.			1.00
20	22920300	THREAD RELEASE SUPPORTING PIN			1.00
21	11018009	TENSION RELEASE PLATE			1.00
22	11018108	TENSION RELEASE SHAFT			1.00
23	22907505	PRESSER SPRING REGULATOR			1.00
24	22907604	PRESSER SPRING REGULATOR NUT			1.00
25	22907703	PRESSER GUIDE BAR			1.00
26	22907406	PRESSER SPRING			1.00
27	11006004	PRESSER BAR GUIDE BRACKET			1.00
28	22907000	PRESSER BAR			1.00
29	22907307	THREAD GUIDE			1.00
30	SS8660810TP	SCREW 1/4-40 L=8			1.00
31	SS6090910SP	SCREW 9/64-40 L=9			2.00
32	22907109	PRESSER BAR BUSHING, LOWER			1.00
33	SS7091110TP	SCREW 9/64-40 L=10.5			1.00
34	11028172	PRESSER FOOT ASM.	FOR USE IN JAPAN		1.00
35	B15245520BA	PRESSER FOOT ASM.	FOR JA		1.00

FEED MECHANISM COMPONENTS

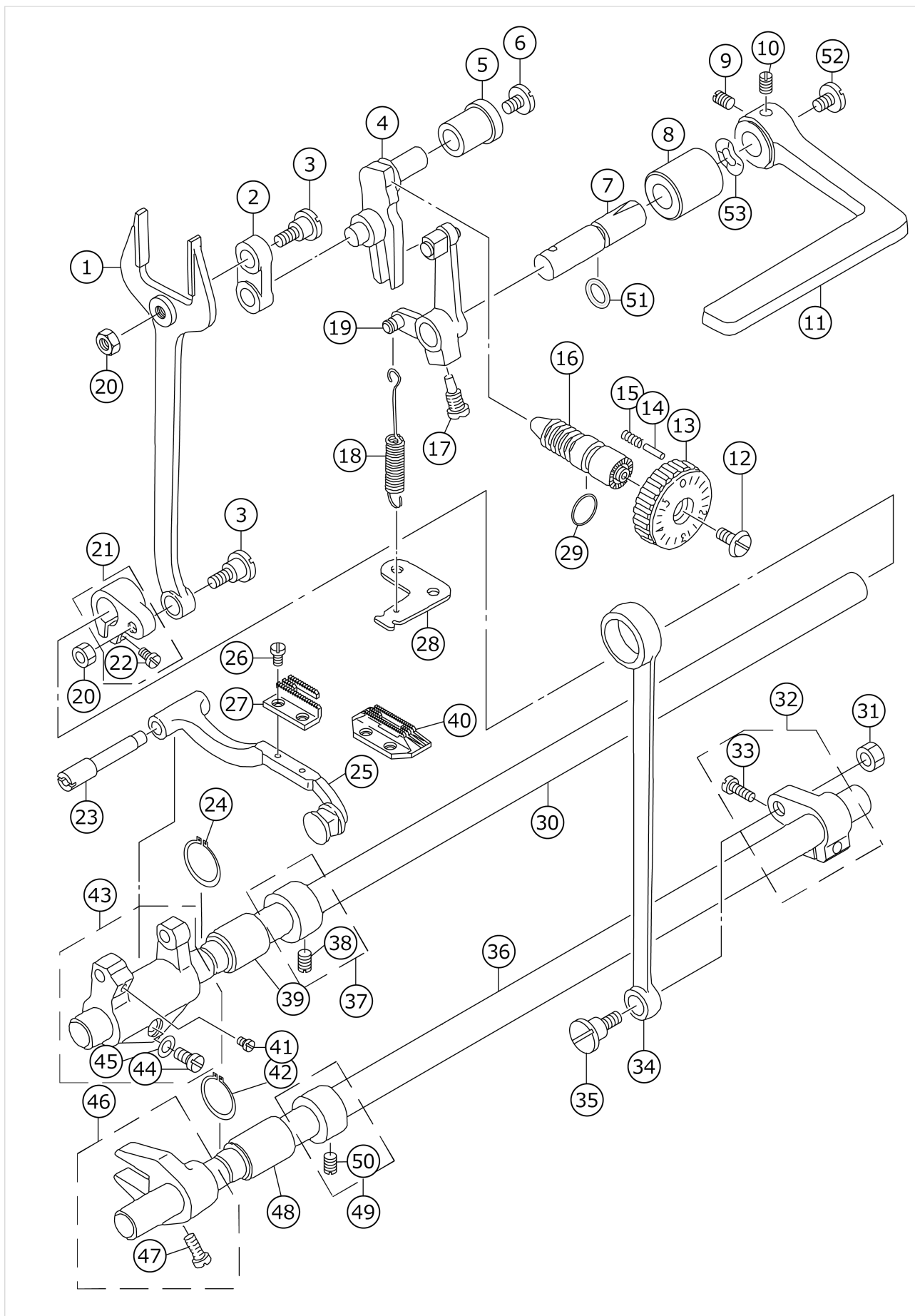

No.	parts number	parts name	comment	child	num
1	11050200	PITMAN			1.00
2	11050309	PITMAN LINK			1.00
3	SD1000801SH	HINGE SCREW D=10 H=8			2.00
4	11050507	FEED REGULATOR			1.00
5	22911705	FEED REGULATOR BUSHING			1.00
6	SS7120770SH	SCREW 3/16-28 L=7			1.00
7	11053105	FEED REVERSE SHAFT			1.00
8	11010709	FEED LEVER METAL			1.00
9	SM8061010TP	SCREW			1.00
10	SM8061050TP	SCREW			1.00
11	22912703	FEED LEVER			1.00
12	SS6121860SP	SCREW 3/16-28 L=18			1.00
13	22911903	FEED DIAL			1.00
14	22912000	FEED REGULATOR PIN			1.00
15	22912109	FEED REGULATOR PIN SPRING			1.00
16	22911804	FEED REGULATOR SCREW			1.00
17	11010410	FEED REVERSE ARM SCREW			1.00
18	11050705	LEVER RETURN SPRING			1.00
19	11050655	LEVER CRANK ASM.			1.00
20	NS6680410SP	NUT 9/32-28			2.00
21	11050408	FEED ROCK SHAFT CRANK			1.00
22	SS7121610SP	SCREW 3/16-28 L=15.5			1.00
23	22940803	FEED BAR SHAFT			1.00
24	RC0150001KP	RETAINING RING 13.8			1.00
25	22971857	FEED BASE ASM.			1.00
26	SS4080620TP	SCREW 1/8-44 L=6			2.00
27	B1613012A00	FEED DOG A			1.00
28	22913701	FEED SPRING HOOK			1.00
29	RO092270200	RUBBER RING			1.00
30	22912901	FEED ROCKER SHAFT			1.00
31	NS6680410SP	NUT 9/32-28			1.00
32	22915151	FEED ARM COMPL.			1.00
33	SS7121610SP	SCREW 3/16-28 L=15.5			1.00
34	22915003	CONNECTING ROD			1.00
35	SD1000801SH	HINGE SCREW D=10 H=8			1.00
36	22915201	FEED DRIVING SHAFT			1.00
37	22904155	MAIN SHAFT THRUST COLLAR ASM.			1.00
38	SS8660610TP	SCREW 1/4-40 L=6			2.00
39	22913008	FEED ROCKER SHAFT BUSHING			1.00
40	B1613012I00	FEED DOG I	FOR JA,JH		1.00
41	SS7110740TP	SCREW 11/64-40 L=7			1.00
42	RC0150001KP	RETAINING RING 13.8			1.00
43	22940654	FEED ROCKER ASM.			1.00
44	SS7121410TP	SCREW 3/16-28 L=14			1.00
45	WP0480856SP	WASHER 4.8X8.4X0.8			1.00
46	22915359	DRIVING SHAFT CRANK ASM.			1.00
47	SS7111120SP	SCREW 11/64-40 L=10.5			1.00
48	22913008	FEED ROCKER SHAFT BUSHING			1.00
49	22904155	MAIN SHAFT THRUST COLLAR ASM.			1.00
50	SS8660610TP	SCREW 1/4-40 L=6			2.00

51	RO078190100	RUBBER RING				1.00
52	SS7620750SP	SCREW 3/16-32 L= 6.5				1.00
53	WZ1250300K0	WAVED WASHER 12.5X17X0.3				1.00

OIL LUBRICATION COMPONENTS

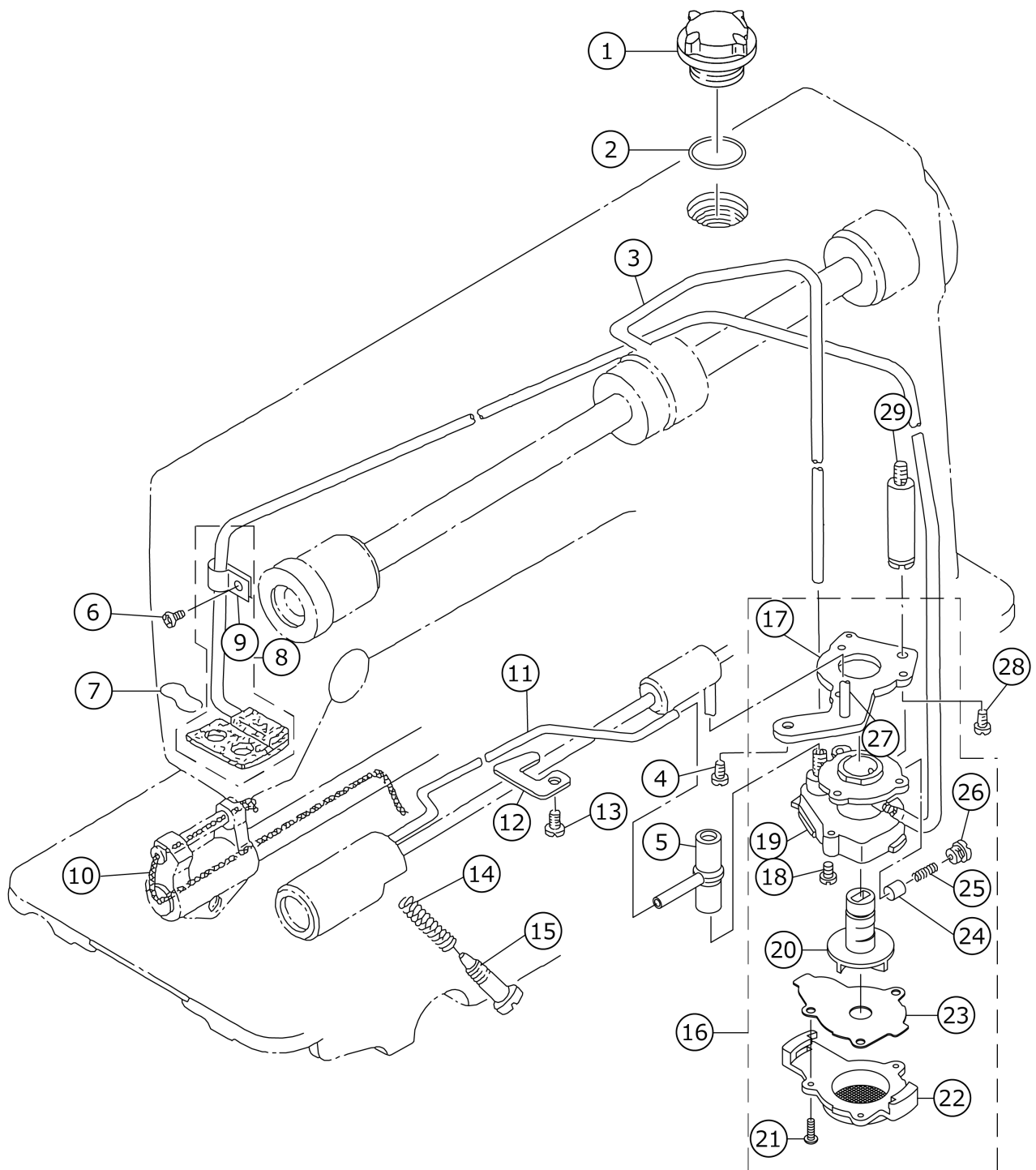

No.	parts number	parts name	comment	child		num
1	B3530555000	OIL SIGHT WINDOW				1.00
2	RO195240100	RUBBER RING				1.00
3	22924401	MAIN SHAFT OIL TUBE				1.00
4	SS4150915SP	SCREW 15/64-28 L=9				1.00
5	22924609	RUBBER JOINT				1.00
6	SS4120615SP	SCREW 3/16-28 L=6				1.00
7	22925101	OIL FELT PRESSER				1.00
8	22924153	RETURN PIPE ASM.				1.00
9	22924302	RETURN PIPE HOLDER				1.00
10	CQ252000000	OIL WICK				0.30
11	22924500	HOOK OIL TUBE				1.00
12	22924807	PIPE HOLDER, LOWER				1.00
13	SS4150915SP	SCREW 15/64-28 L=9				1.00
14	22924906	OIL REGULATOR SCREW SPRING				1.00
15	22925002	OIL REGULATOR SCREW				1.00
16	22923056	OIL PUMP ASM.				1.00
17	22923304	PUMP BODY INSTALLING PLATE				1.00
18	SL4030851SF	SCREW M3 L=8				3.00
19	22923007	PUMP BODY				1.00
20	22923700	IMPELLER				1.00
21	SE4301041SR	SCREW D=3 L=10				3.00
22	22923205	PUMP BODY COVER				1.00
23	22923809	PUMP BODY SUPPORT PLATE				1.00
24	22923403	PLUNGER				1.00
25	22923601	PLUNGER SPRING				1.00
26	22923502	PLUNGER SCREW				1.00
27	22923908	HOOK DRIVING SHAFT OILING PIPE				1.00
28	SS6111010TP	SCREW 11/64-40 L= 9.5				1.00
29	22924005	PUMP BODY STRUT				1.00

OIL RESERVOIR COMPONENT

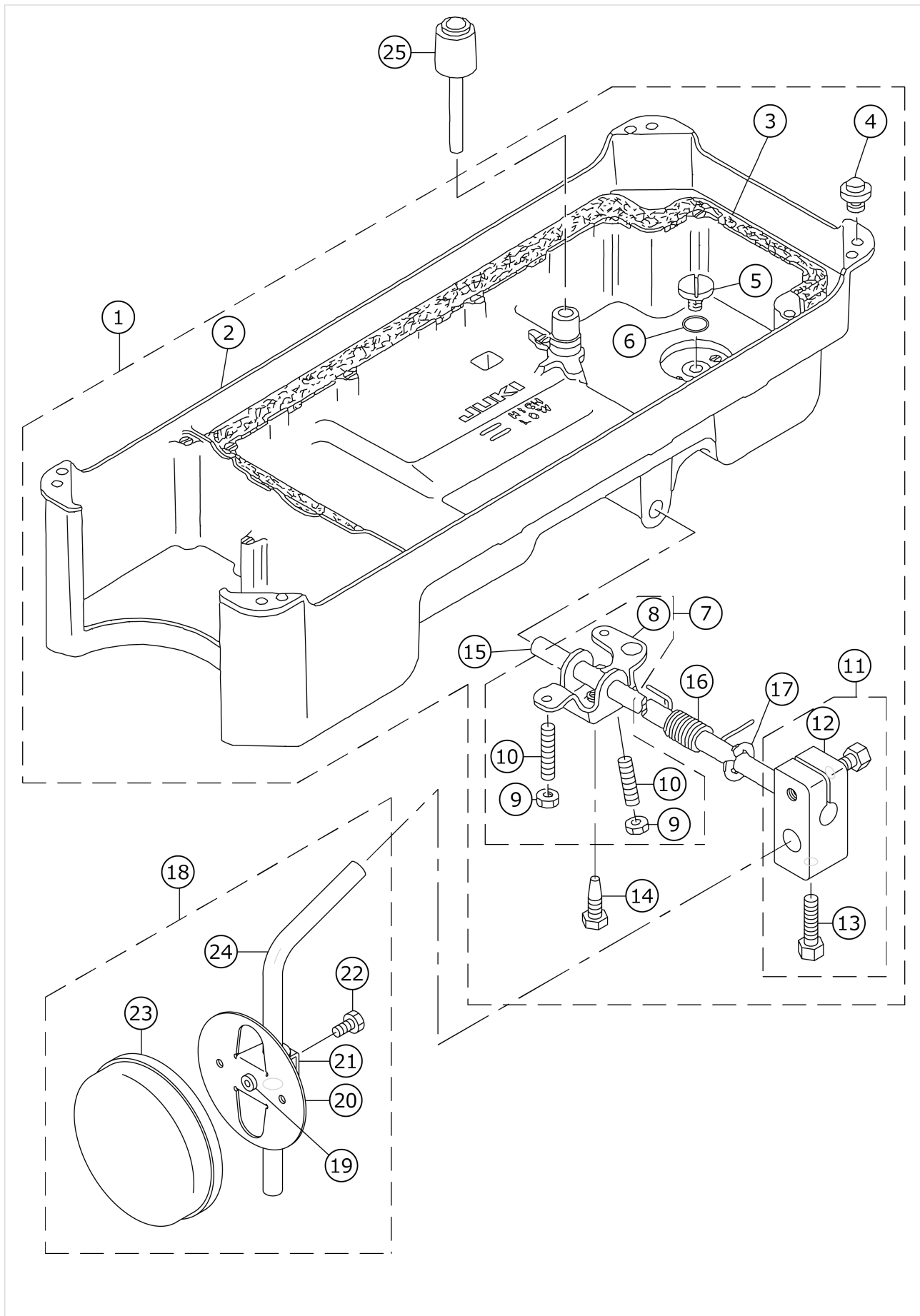

No.	parts number	parts name	comment	child		num
1	11047057	OIL RESERVOIR ASM.				1.00
2	11023017	OIL RESERVOIR				1.00
3	11024700	GASKET				1.00
4	11047107	RUBBER CUSHION				4.00
5	SS6700710SH	SCREW 5/16-24 L=7				1.00
6	RO098240100	RUBBER RING				1.00
7	22932156	KNEE LIFTER ROTATION ARM ASM.				1.00
8	22932107	KNEE LIFTING ROTATING ARM				1.00
9	NM6060001SE	NUT M6				2.00
10	SM8063012TR	SCREW M6 L=30				2.00
11	22932453	BRACKET ASM.				1.00
12	22932404	BRACKET				1.00
13	22934707	SCREW				2.00
14	SM9061853SR	SCREW M6 L=17.5				1.00
15	22932305	KNEE PRESS ROD				1.00
16	22932206	SPRING				1.00
17	RE1000000K0	E-RING 10				1.00
18	22934251	KNEE PAD PLATE ASM.				1.00
19	22934400	KNEE PAD PLATE RUBBER				1.00
20	22934202	KNEE PAD PLATE				1.00
21	22934301	KNEE PAD PLATE SUPPORT				1.00
22	SM9061203SE	SCREW M6 L=12				1.00
23	22934509	KNEE PAD PLATE COVER				1.00
24	22934608	KNEE PAD UPRIGHT SHAFT				1.00
25	11024304	KNEE PRESS LIFTER ROD				1.00

BELT COVER & BOBBIN WINDER COMPONENTS

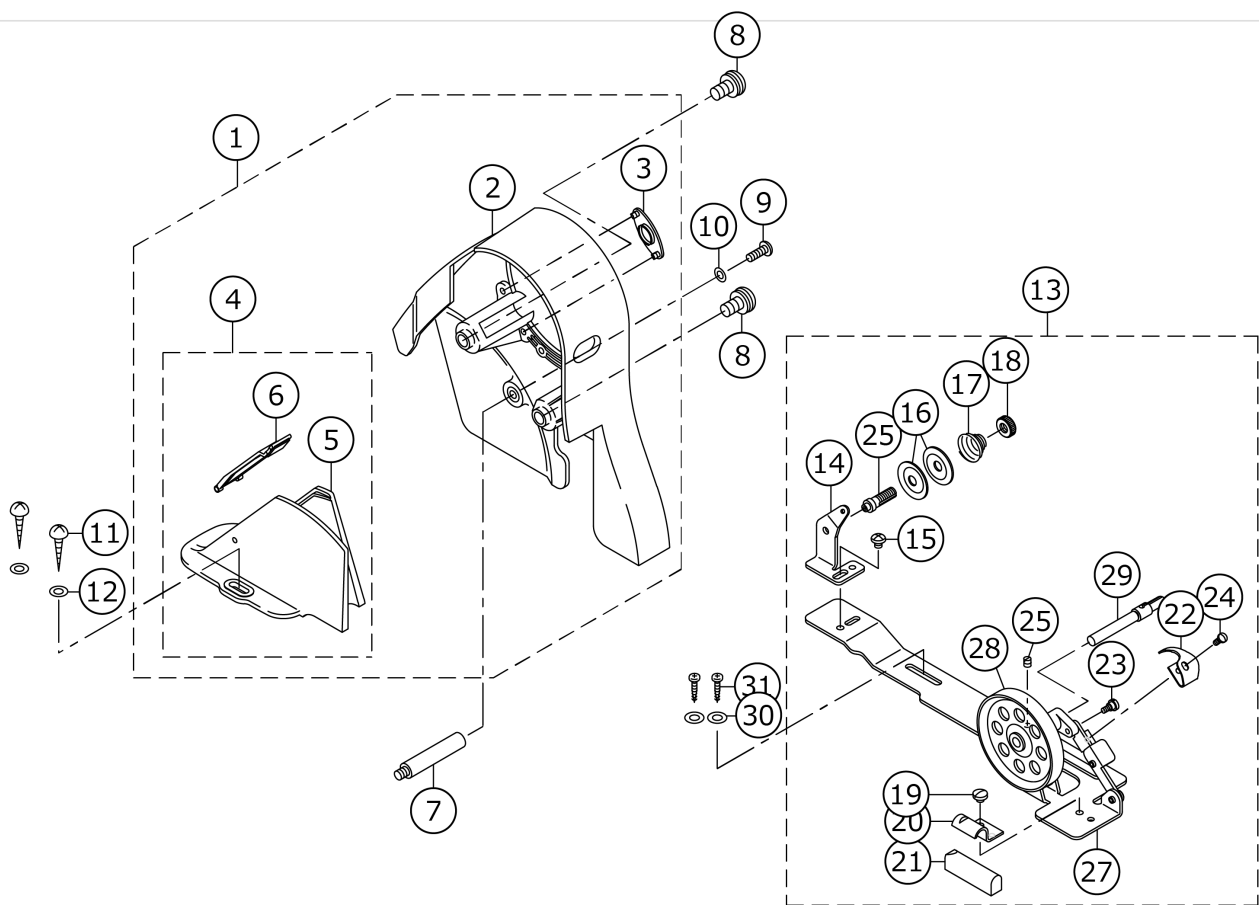

No.	parts number	parts name	comment	child		num
1	11076650	BELT COVER ASM. (URBANE GREY)				1.00
2	11076601	BELT COVER A				1.00
3	11076700	BELT COVER A CAP				1.00
4	11076858	BELT COVER B ASM.				1.00
5	11076809	BELT COVER B				1.00
6	11076957	BELT COVER B CAP ASM.				1.00
7	11023504	BELT COVER SUPPORT, A				1.00
8	11025202	BELT COVER A SCREW				2.00
9	SS4121415SP	SCREW 3/16-28 L=14				1.00
10	WP0501016SD	WASHER 5X10.5X1				1.00
11	SK3412000SC	WOOD SCREW D=4.1 L=20				2.00
12	WP0450826SC	WASHER 4.5X10X0.8				2.00
13	22927354	BOBBIN WINDER COMPL.				1.00
14	22928501	THREAD TENSION POST BASE				1.00
15	SS4110515SP	SCREW 11/64-40 L=5				1.00
16	22928907	THREAD TENSION DISK				2.00
17	22929004	THREAD TENSION SPRING				1.00
18	22928808	NUT				1.00
19	SS7110350SP	SCREW 11/64-40 L=3.5				1.00
20	22928402	CONTROL RUBBER HOLDING PLATE				1.00
21	22928303	CONTROL RUBBER				1.00
22	22928105	BOBBIN PRESSER				1.00
23	SD0490261SP	HINGE SCREW D=4.9 H=2.6				1.00
24	SS7081310SP	SCREW 1/8-44 L=12.5				1.00
25	22928709	THREAD TENSION POST				1.00
26	22927305	BOBBIN WINDER BASE				1.00
27	22927404	BOBBIN WINDER				1.00
28	22927602	BOBBIN WINDER SPINDLE				1.00
29	SS8110510SP	SCREW 11/64-40 L=5				1.00
30	WP0450826SC	WASHER 4.5X10X0.8				2.00
31	SK3412000SC	WOOD SCREW D=4.1 L=20				2.00

THREAD STAND COMPONENTS

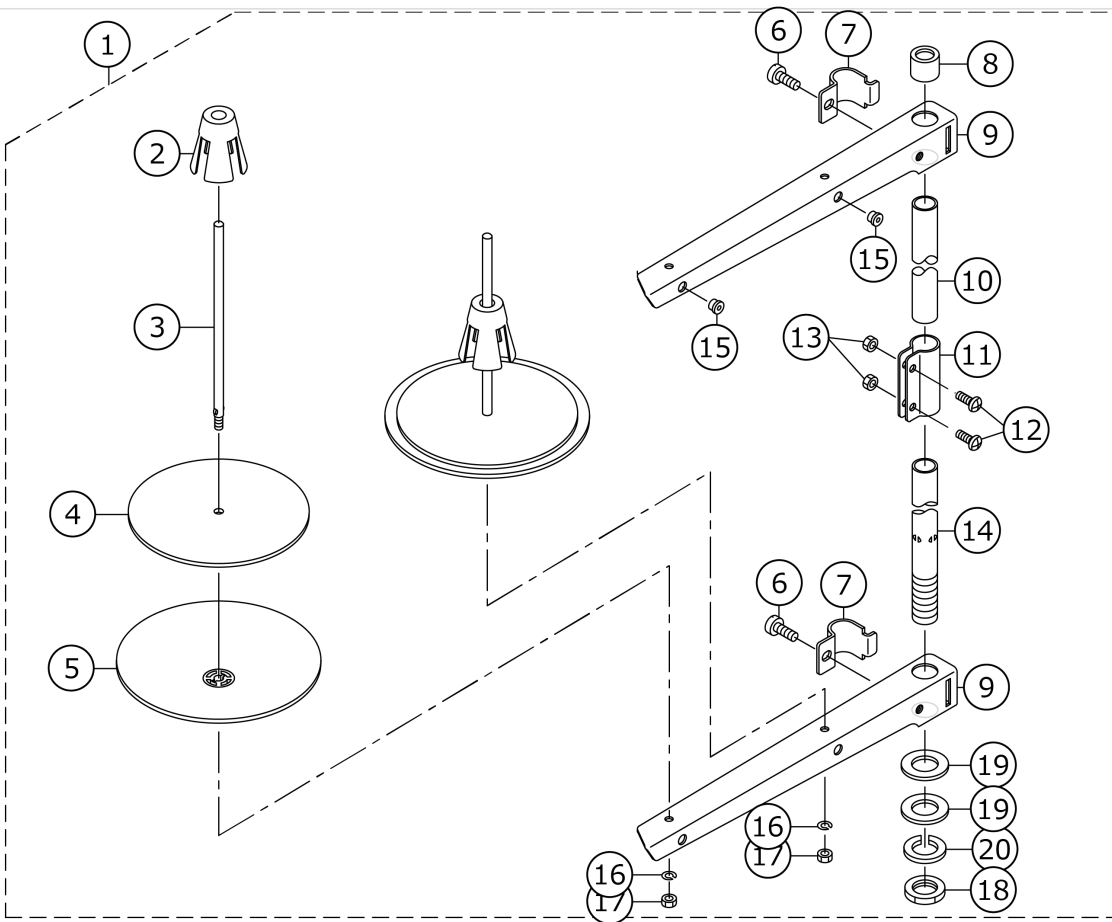

No.	parts number	parts name	comment	child		num
1	22930358	THREAD STAND ASM.				1.00
2	22931109	SPOOL RETAINER				2.00
3	22931000	SPOOL PIN				2.00
4	22930903	SPOOL REST CUSHION				2.00
5	22930804	SPOOL REST				2.00
6	SM6061610SC	SCREW M6 L=16				2.00
7	22930705	THREAD GUIDE ARM JOINT				2.00
8	22931406	SPOOL REST ROD RUBBER CAP				1.00
9	22930507	SPOOL REST ARM				2.00
10	22930408	SPOOL REST ROD, UPPER				1.00
11	22931307	SPOOL REST ROD JOINT				1.00
12	SM4051405SE	SCREW M5 L=14				2.00
13	NM6050001SE	NUT M5				2.00
14	22930309	SPOOL REST ROD, LOWER				1.00
15	22931208	THREAD GUIDE				2.00
16	WS0510002KN	SPRING WASHER				2.00
17	NM6050001SE	NUT M5				2.00
18	NM6160511SE	NUT M16X1.5				1.00
19	WP1612616SE	WASHER 16X30X2.6				2.00
20	WS1643202KR	SPRING WASHER				1.00

EXCLUSIVE PARTS FOR DDL-5530NH

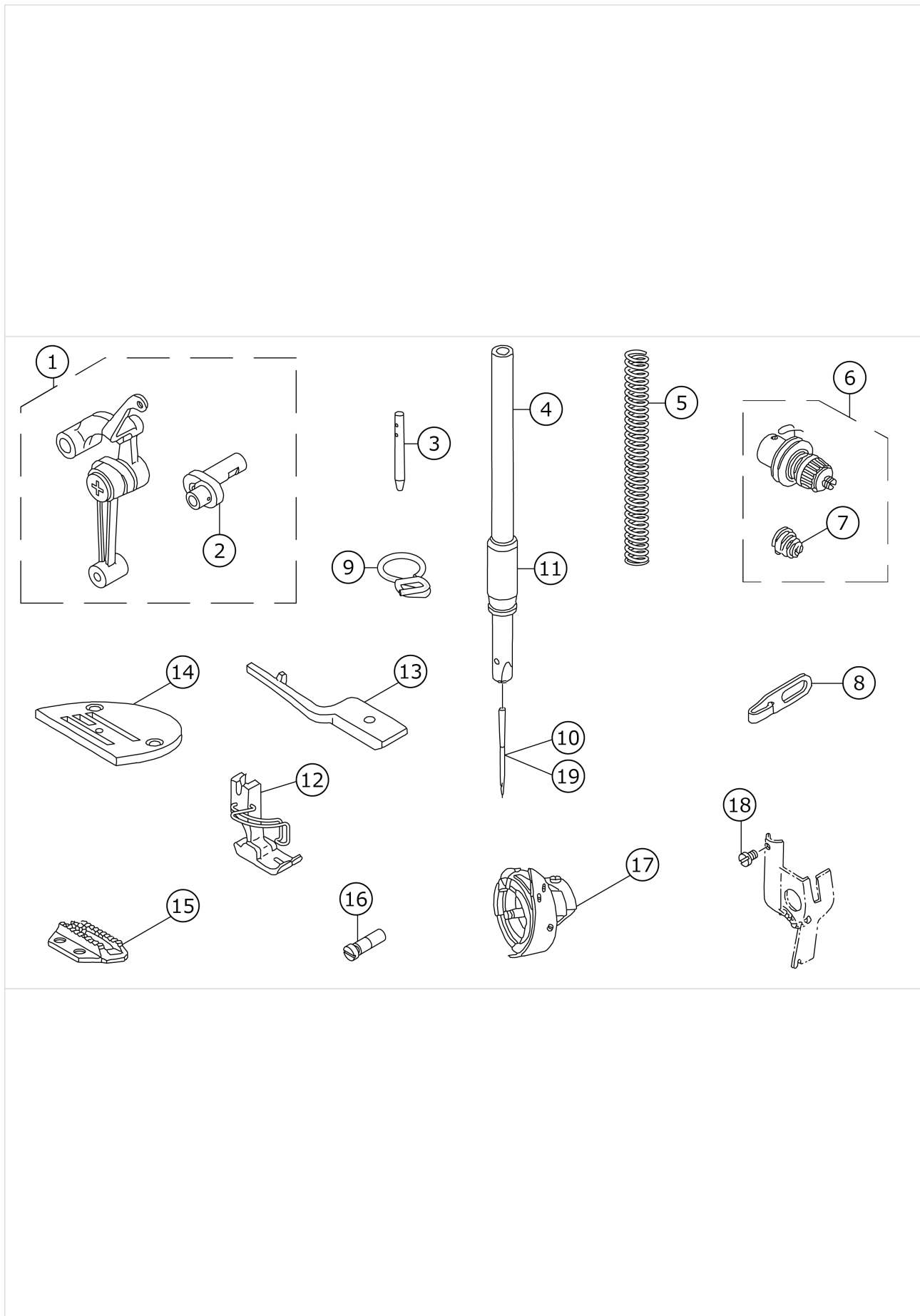

No.	parts number	parts name	comment	child		num
1	11091659	LINK THREAD TAKE-UP LEVER ASM.				1.00
2	11091600	NEEDLE BAR CRANK H				1.00
3	22958300	NEEDLE THREAD GUIDE PIN				1.00
4	11091303	NEEDLE BAR				1.00
5	B1505552000A	PRESSER SPRING				1.00
6	11073657	THREAD TENSION ASM.				1.00
7	B3114232000	THREAD TENSION SPRING				1.00
8	11091006	ARM THREAD GUIDE (HA)				1.00
9	B1419553000	NEEDLE BAR THREAD GUIDE				1.00
10	MC200501300	NEEDLE 134 NM130	FOR JE			1.00
11	B1403553000	NEEDLE BAR BUSHING, LOWER				1.00
12	D1524555EBL	PRESSER FOOT ASM.				1.00
13	11091709	POSITIONING FINGER				1.00
14	B1109555H0B	THROAT PLATE (H)				1.00
15	B1613555H00	FEED DOG (H)				1.00
16	B1213552000A	OIL ADJUSTING PIN				1.00
17	11092459	LUBRICATING HOOK ASM.				1.00
18	SS6080320SP	SCREW 1/8-44 L= 2.5				1.00
19	MDB100B2100	NEEDLE DBX1 #21				1.00

EXCLUSIVE PARTS FOR DDL-5530NA

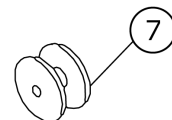
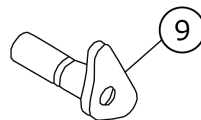
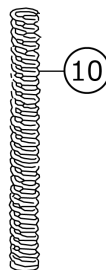
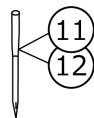
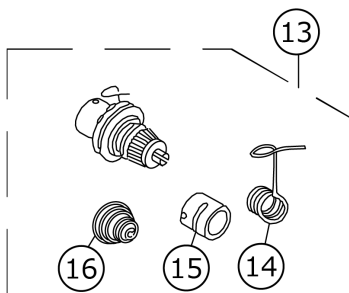
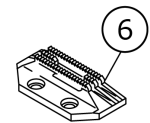
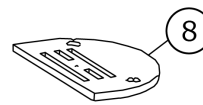
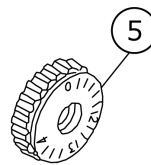
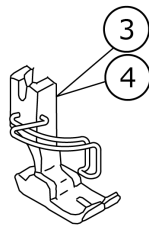
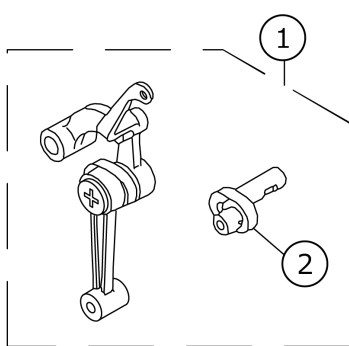

No.	parts number	parts name	comment	child		num
1	11091865	LINK THREAD TAKE-UP LEVER ASM.				1.00
2	11091808	NEEDLE BAR CRANK A				1.00
3	11028172	PRESSER FOOT ASM.	FOR USE IN JAPAN			1.00
4	B15240120BA	PRESSER FOOT ASM.				1.00
5	11072006	FEED DIAL				1.00
6	B1613012I00	FEED DOG I				1.00
7	B9117552A00	BOBBIN				1.00
8	B1109012I0B	THROAT PLATE (I)				1.00
9	11092558	HAND LIFTER CAM ASM.				1.00
10	B1505227T00A	PRESSER SPRING T				1.00
11	MDA100B0900	NEEDLE DAX1 #9				1.00
12	MC200500650	NEEDLE 134 NM65	FOR JE			1.00
13	11073756	THREAD TENSION ASM.				1.00
14	D3128555D00	TAKE-UP SPRING				1.00
15	B3111126000	TENSION POST SOCKET				1.00
16	D3129555D00	THREAD TENSION SPRING				1.00

EXCLUSIVE PARTS FOR DDL-5530NL

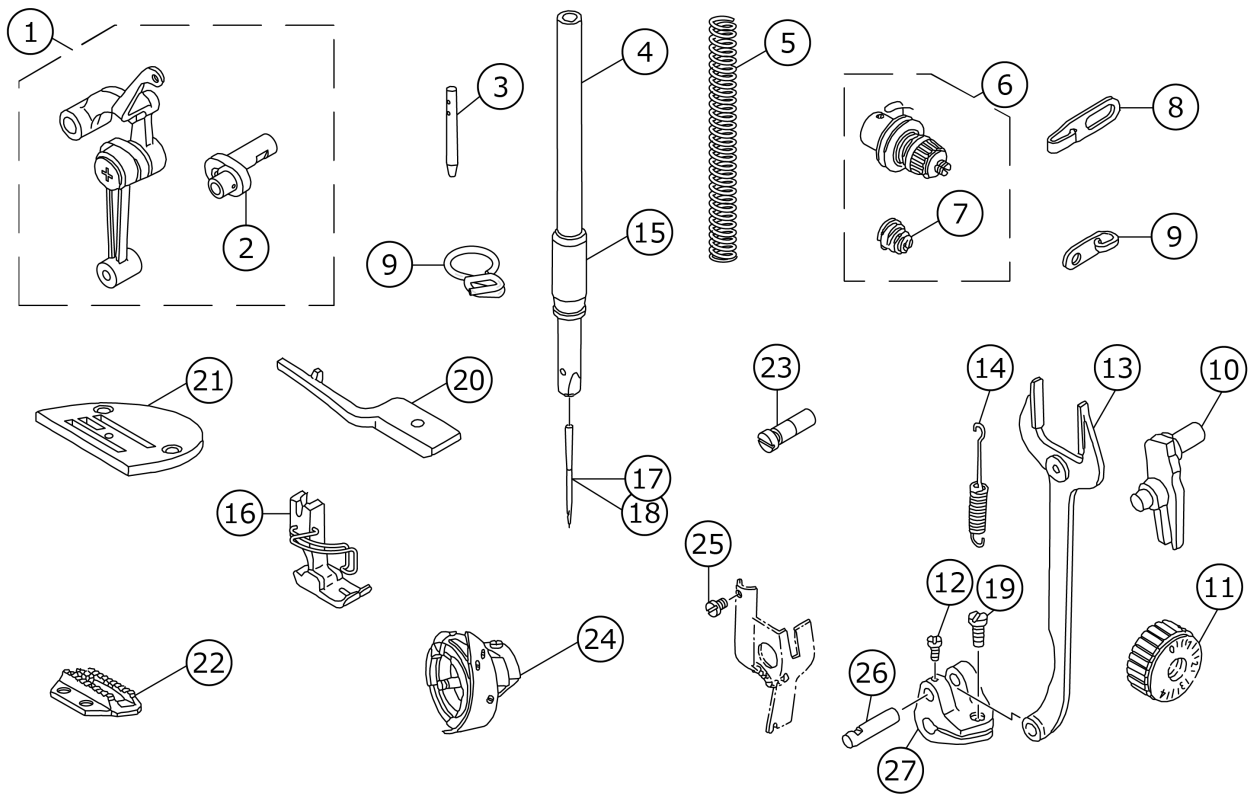

No.	parts number	parts name	comment	child		num
1	11091659	LINK THREAD TAKE-UP LEVER ASM.				1.00
2	11091600	NEEDLE BAR CRANK H				1.00
3	22958300	NEEDLE THREAD GUIDE PIN				1.00
4	11091303	NEEDLE BAR				1.00
5	B1505552000A	PRESSER SPRING				1.00
6	11073558	THREAD TENSION ASM.				1.00
7	B3114232000	THREAD TENSION SPRING				1.00
8	11091006	ARM THREAD GUIDE (HA)				1.00
9	B1419553000	NEEDLE BAR THREAD GUIDE				1.00
10	11060209	FEED REGULATOR, L				1.00
11	11074804	FEED DIAL				1.00
12	SS7110910SP	SCREW 11/64-40 L=8.5				1.00
13	11060001	PITMAN, L				1.00
14	11060506	LEVER RETURN SPRING				1.00
15	B1403553000	NEEDLE BAR BUSHING, LOWER				1.00
16	B1524041EBO	PRESSER FOOT ASM.				1.00
17	MDB100B2100	NEEDLE DBX1 #21				1.00
18	MC200501300	NEEDLE 134 NM130	FOR JE			1.00
19	SS6121210SP	SCREW 3/16-28 L=12				1.00
20	11091709	POSITIONING FINGER				1.00
21	B1109555H0B	THROAT PLATE (H)				1.00
22	B1609201000A	FEED DOG(A)				1.00
23	B1213552000A	OIL ADJUSTING PIN				1.00
24	11092459	LUBRICATING HOOK ASM.				1.00
25	SS6080320SP	SCREW 1/8-44 L= 2.5				1.00
26	B1607560000	FEED ROCKER SHAFT CRANK PIN				1.00
27	11060100	FEED ROCK SHAFT CRANK				1.00

LIST FOR INFORMATION OF CHANGE (1)

As to the place changed, refer to the corresponding Rev.No.
 When previous parts(Obsoleted part)and new parts(Added parts)are
 not interchangeable with each other:
 In this case, even obsoleted parts(D.)can be ordered with the
 obsoleted part number, so select the parts with changed dates and
 place your orders.

変更箇所は、該当Rev.No.版をご参照ください。

部品の互換性がない変更の場合は、削除された品番でも、ご注文できます。
 29134608

No.0923-05...Rev.No.

*A:Added parts追加部品/D:Obsoleted parts削除部品/E:Erratum訂正

* Rev. No.	Page 頁	Ref. No.	Parts No. 品番	* Rev. No.	Page 頁	Ref. No.	Parts No. 品番
D 04	2	9	110-00619	A 05	2	9	110-03308
D 04	2	18	114-00405	A 05	2	18	229-00609
D 04	2	23	110-72253	A 05	2	23	229-45356
D 04	2	24	110-72204	A 05	2	24	229-21308
D 04	2	25	B3120-125-000	A 05	2	25	229-21407
D 04	2	26	B3129-012-A00	A 05	2	26	229-21704
D 04	2	27	B3132-552-000	A 05	2	27	229-21803
D 04	2	28	B3126-012-000	A 05	2	28	229-21506
D 04	2	29	B3115-552-000	A 05	2	29	229-21209
D 04	2	30	B3128-012-000	A 05	2	30	229-21605
D 04	2	31	B3111-552-B00	A 05	2	31	229-45307
D 04	2	33	SS-8150710-SP	A 05	2	33	SS-8150710-TP
D 04	2	34	B3118-552-E00	A 05	2	34	229-20904
D 04	2	45	110-01104	A 05	2	45	229-01003
D 04	2	48	114-15205	A 05	2	48	229-01904
D 04	4	1	SS-8151150-SP	A 05	4	1	SS-8151150-TP
D 04	4	22	CS-147121A-SH	A 05	4	22	229-04155
D 04	4	25	110-02300	A 05	4	25	229-03306
D 04	4	31	110-03001	A 05	4	31	229-03900
D 04	6	1	B1405-012-000	A 05	6	1	229-01409
D 04	6	26	110-15108	A 05	6	26	110-15807
D 04	6	36	110-15955	A 05	6	36	229-16555
D 04	6	38	B1808-552-000	A 05	6	38	229-16506
D 04	6	40	B9117-012-000	A 05	6	40	229-32909
D 04	6	44	MDP-500B1400				
D 04	8	1	110-71800	A 05	8	1	229-07802
D 04	8	11	110-07101	A 05	8	11	229-08909
D 04	8	20	110-18306	A 05	8	20	229-20300
D 04	8	23	110-71602	A 05	8	23	229-07505
D 04	8	24	110-71701	A 05	8	24	229-07604
D 04	8	33	SS-7091110-SP	A 05	8	33	SS-7091110-TP
D 04	10	14	110-52701	A 05	10	14	229-12000
D 04	10	40	B1613-552-000	A 05	10	40	B1613-012-I00
D 04	10	53	B1613-012-I00				
D 04	12	5	110-21409	A 05	12	5	229-24609
D 04	12	15	B3514-412-000	A 05	12	15	229-25002

HOW TO MAKE USE OF THIS PARTS LIST

1.Explanation of codes

1)"*"mark.....means this part is changed from the previous parts book.

As to the details of the change, refer to the "List for information of change".

2)"#01".....refer to "Note" explanation at bottom of page.

2.Codes on the "Qty" column

· Each numeral indicates the number of parts required.

· "0.1" and "2.5" indicate the length (in meters) of the respective parts.

3.Parentheses mean that the corresponding part is a subpart that constructs an assembly part.

4.Dotted lines on the Figures indicate assembly parts.

1."注記"欄の記号説明

1) "*"印.....前回のパーツブックに比較して今回変更された部品を意味します。

変更内容は、"変更情報リスト"を参照してください。

2) "#01".....ページ下の"注記"の説明を参照してください。

2.数量欄の数字は、個数を表し、0.1、2.5等の数値は、長さ（単位メートル）を表します。

3.数量欄の（ ）は、組部品を構成している子部品であることを意味します。

4.イラストページの-----枠は、組構成であることを意味します。

